

10

LAVORAZIONE DEL SUOLO
CULTIVATION EQUIPMENT
TRAVAIL DU SOL
BODENBEARBEITUNG
TRABAJOS DE TIERRA

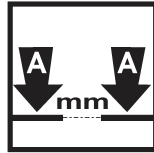

PESO
WEIGHT
POIDS
GEWICHT
PESO



SEZIONE
SECTION
SECTION
ABSTAND
SECCIÓN

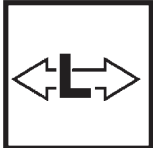

LUNGHEZZA
LENGTH
LONGEUR
LÄNGE
LARGURA

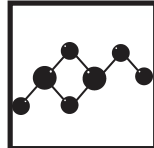

MATERIALE
MATERIAU
MATERIAL
MATERIAL
MATERIAL



DIAMETRO
DIAMETER
DIAMÈTRE
DURCHMESSER
DIAMETRO

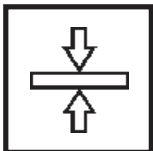

SPESSORE
THICKNESS
ÉPAISSEUR
STÄRKE
ESPESOR



FILETTATURA
FILETAGE
THREAD
GEWINDE
ROSCA



**APPLICAZIONE/
IMPIEGHI**
APPLICATION/USE
APPLICATION/UTILISATION
ANWENDUNG/EISANTZ
MONTAJE/USO



DESCRIZIONE
DESCRIPTION
DESCRIPTION
BESCHREIBUNG
DESCRIPCIÓN



RIF. ORIGINALE
ORIGINAL REF.
REF. D'ORIGINE
ORIGINAL ERSATZTEIL NR.
REF. ORIGINAL



NOTE
NOTES
NOTES
NOTE
NOTAS

MOLLE PER VIBROCOLTIVATORI E SOCS REVERSIBILI

DENTS POUR VIBROCOLTEUR ET SOCS REVERSIBLES

VIBROTILLER SPRNGS AND REVERSIBLE SOCS

EGGEN UND KULTIVATORZINKEN

MUELLES PARA VIBRACULTIVADORES Y SOCS REVERSIBLES



start



MOLLE TIPO "FLEX" PER VIBROCOLTIVATORI

DENT DE VIBROCOLTEUR

CULTIVATOR SPRING TINE "FLEX"

KULTIVATORZINKE "FLEX"

MUELLES TIPO "FLEX" PARA VIBRO CULTIVADORES

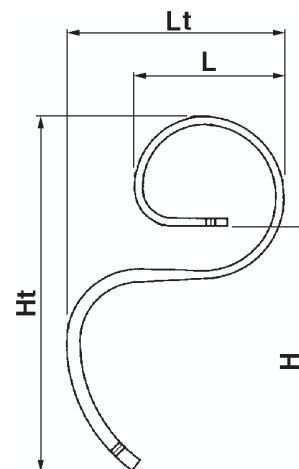
Standard - Alta - Larga**Scorrevole****Diritta**

ATTENZIONE: Il vomerino reversibile a ricambio è applicabile solamente alle molle fornite con vomere montato. Le molle fornite prive di vomere non possono montarlo in quanto sono prive di foro di fissaggio (è la molla stessa che fa da vomerino con il suo terminale).

N.B.: Le misure sono indicative, e possono essere soggette a variazioni senza alcun obbligo di preavviso da parte nostra.

Art.		Tipo/Type		Vomere se compreso			Misure mm.			
Senza vomere *	Con vomere				s/vomere	c/vomere	Lt	L	Ht	H
-	S.4420.0005	Standard	32 x 10	S.7636.0002	2,60	2,92	320	220	530	370
S.4420.0006	S.4410.0001		32 x 12	S.7636.0002	3,00	3,32	325	225	535	370

* Non possono montare il vomerino in quanto privi di foro di fissaggio.

RINFORZI PER MOLLE "FLEX"

RENFORT DE DENT

FLEX AUXILIARY SPRINGS

VERSTÄRKUNG FÜR KULTIVATORZINKEN "FLEX"

REFUERZO PARA MUELLES "FLEX"

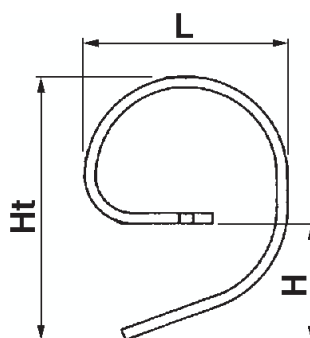
**Standard****Con occhio**

Art.	Tipo/Type			Misure mm.		
				L	Ht	H
S.6010.0001	Standard	32 x 10	1,43	190	250	110
S.6010.0002	Con occhio	32 x 10	1,55	190	280	140

VOMERINI REVERSIBILI PER MOLLE FLEX

SOC POUR DENT DE VIBRO-CULTEUR
 BLADES FOR CULTIVATOR TINES
 DREHBARE SCHARE FÜR KULTIVATORZINKEN "FLEX"
 REJAS ABATIBLES PARA MUELLES FLEX

Art.	Misure mm.	Kg.	
S.7636.0002	35 x 5 x 190	0,30	Molle flex varie
S.7636.0009	40 x 6 x 190	0,25	
S.7636.0010	50 x 6 x 265	0,63	Molle flex 45x12

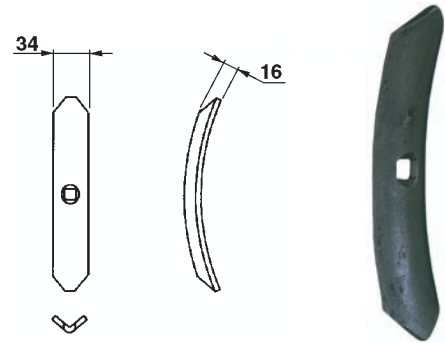

VOMERINI A CUORE PER MOLLE FLEX

SOC COEUR POUR VIBRO-CULTEUR
 CULTIVATOR BLADE
 GÄNSEFUSSSCHARE FÜR KULTIVATORZINKEN
 REJAS A CORAZÓN PARA MUELLES FLEX

Art.	L mm.	H mm.	Sp. mm.	Kg.
S.7636.0008	105	125	4	0,22

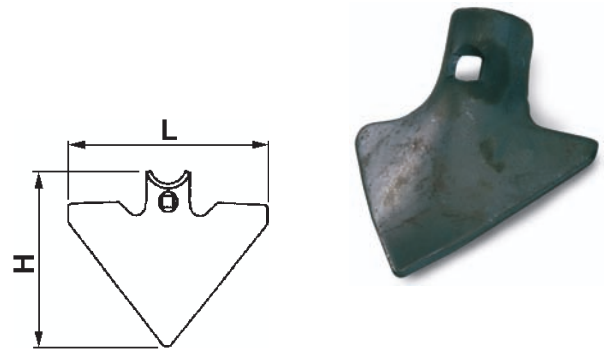



VITI TESTA OVALE PER VOMERI

BOULON À TÊTE OVALE COLLET CARRÉ
 OVAL SCREWS FOR BLADES
 SCHRAUBEN MIT OVALEM KOPF FÜR SCHARE
 TORNILLOS CABEZAS OVALES PARA REJAS

Viti complete di dado con testa ovale e quadro sottotesta per il fissaggio dei vomerini alle molle tipo Flex.
 Materiale 8.8



Art.			Quadro
S.0565.0001	M10	38	10

STAFFE PER MOLLE

ÉTRIER DE FIXATION DE DENT SUR CHASSIS
 CULTIVATOR TINE FRAME
 HALTERUNG FÜR FEDERZINKEN
 ESTRIBOS PARA MUELLES



Art.	Telaio	Molla	Rinforzo
Staffa bilama			
S.6482.0001	50 x 12	32 x 12	32 x 10

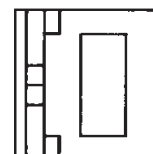

Staffe modello 50 x 6

VITI TESTA TONDA SVASATA PER VOMERINI

BOULON À TÊTE FRAISÉE COLLET CARRÉ
 COUNTERSUNK ROUND HEAD SREW FOR BLADES
 KONISCHE RUNDSCHRAUBE FÜR SCHARE
 TORNILLOS CABEZA REDONDA CÓNICA PARA REJAS

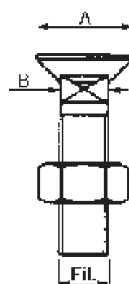

Art.		A	B
S.7400.0006	M 12x50	- 24 mm	12 mm
S.0565.0002	M 12x60		

Viti complete di dado con testa tonda svasata e quadro sottotesta per il fissaggio dei vomerini alle molle di qualsiasi modello e tipo.
 Materiale 4.8

VITI TESTA TONDA SVASATA PER VOMERINI

VIS TÊTE RONDE POUR SOCS
 ROUND HEAD SCREWS FOR SHARES
 KONISCHE RUNDSCHRAUBE FÜR SCHAREN
 TORNILLOS CABEZA REDONDA CÓNICA PARA REJAS

Viti complete di dado con testa tonda svasata e quadro sottotesta per il fissaggio dei vomerini alle molle di qualsiasi modello e tipo.
 Materiale 4.8

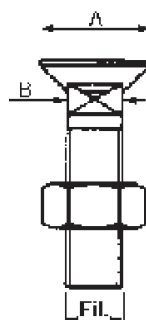

Art.		A	B
S.7400.0006	Bullone - 12x50	- 24 mm	12 mm
S.0565.0002	Bullone - 12x60		

VITI TESTA OVALE PER VOMERI

BOULON À TÊTE OVALE COLLET CARRÉ
 OVAL HEAD SCREWS FOR BLADES
 SCHRAUBEN MIT OVALEM KOPF FÜR SCHARE
 TORNILLO CABEZA OVAL PARA REJAS

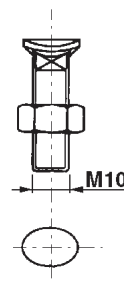

Art.			Quadro
S.0565.0001	M10	38	10

Vite completa di dado con testa ovale e quadro sottotesta per il fissaggio dei vomerini alle molle cancellatraccia. Materiale 8.8

SOCS REVERSIBILI

SOC RÉVERSIBLE
 REVERSIBLE BLADES
 DREHBARE SCHARE
 SOCS REVERSIBLES

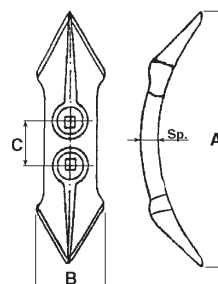

Art.	A mm.	B mm.	C mm.	Sp. mm.
S.7636.0007	260	75	50	8

VOMERINO A SALDARE IN ACCIAIO STAMPATO

SOC A SOUDER EN ACIER FORGÉ
WELD-ON FORGED BLADES
SCHARE ZUM ANSCHWEISSEN
REJA DE SOLDAR DE ACERO ESTAMPADO

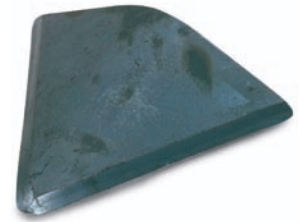
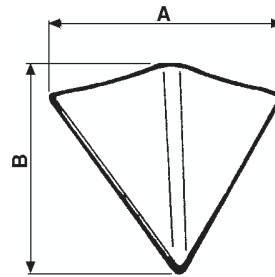

Art.	A mm.	B mm.
S.7636.0003	240	240

VOMERINI A LANCIA PER ANCORA ESTIRPATORE

SOC POUR DENT D' EXTIRPATEUR
BLADE FOR CULTIVATOR TINE
SCHARE FÜR GRUBBERZINKEN
REJAS PARA ANCLA ESTIRPADOR

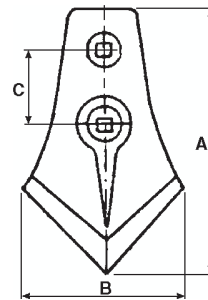

Art.	A mm.	B mm.	C mm.
S.7636.0004	235	125	50

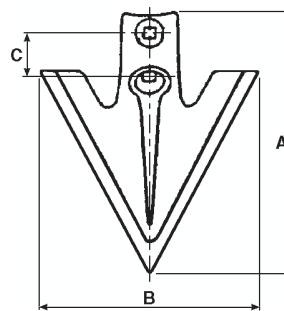

Art.	A mm.	B mm.	C mm.
S.7636.0005	240	190	50

VOMERINI A LANCIA PER ANCORA ESTIRPATORE

SOC POUR DENT D' EXTIRPATEUR
BLADE FOR CULTIVATOR TINE
SCHARE FÜR GRUBBERZINKEN
REJAS PARA ANCLA ESTIRPADOR

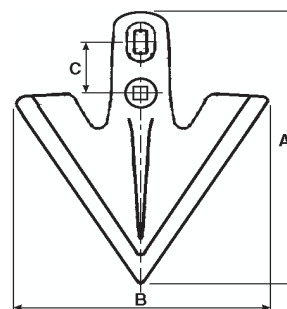

Art.	A mm.	B mm.	C mm.
S.7636.0006	280	240	45/65

PIASTRE DENTATE PER RUSPE LIVELLATRICI

RONDELLE CRÉNELÉE POUR LAME NIVELEUSE
PLATES FOR REAR SCRAPERS
ZAHNSCHEIBEN FÜR PLANIERGERÄTE
PLACAS DENTADAS PARA TRAILLAS NIVELADORA

Art.	Ø mm.	
S.5375.0001	250	Foro Ø 60

